

## Ultrasonic Anemometer Lufft V200A-UMB

S85200H

- **Robust design and precise measurement of wind speed, wind direction, air pressure and calculation of acoustic virtual temperature**
- **Maintenance-free - no mechanical parts**
- **Ideal for renewable energy applications**
- **Heating for use in cold weather climates**



### Description

Extremely precise and maintenance-free measurement of wind velocity and wind direction as well as calculation of acoustic virtual temperature. The ultrasonic wind sensor is seawater-resistant and designed without mechanical parts as they have been used with traditional "cups and vanes". The sensor is heated to remove frost and ice formation from the sensor.

The digital or analog output delivers instantaneous, average, min or max value with flexible measuring rate. We recommend using the Modbus RTU protocol for applications with Ammonit Meteo-40 data loggers.

### Wind speed and direction

The wind measurement element uses 4 ultrasound sensors which take cyclical measurements in all directions. The resulting wind speed and direction are calculated from the measured run-time sound differential.

### Virtual temperature

Due to the physical relationship between the velocity of propagation of sound and the air temperature, the approximate ambient temperature can be determined with the aid of ultrasound sensors.

### Air pressure

The air pressure is measured by an integrated air pressure sensor.

### Dimensional drawing

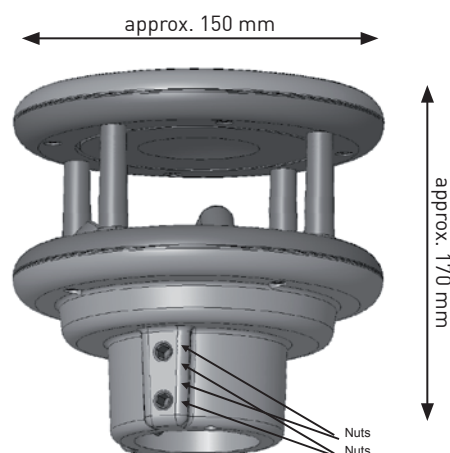

## Ultrasonic Anemometer Lufft V200A-UMB

S85200H

### Specifications

Wind Speed	
Measuring range	0 ... 90 m/s
Accuracy	± 0.3 m/s or 3 % (0 ... 35 m/s) RMS, ± 5 % (>35 m/s) RMS
Resolution	0.1 m/s
Wind Direction	
Measuring range	0 ... 359.9 °
Accuracy	< 3 ° RMSE > 1.0 m/s
Resolution	0.1°
Air Pressure	
Principle	MEMS capacitive
Measuring range	300 ... 1200 hPa
Accuracy	± 1.5 hPa (0...40 °C)
Resolution	0.1 hPa
Virtual Temperature	
Measuring range	-50 ... 70 °C
Accuracy	± 2.0 K (without heater and without solar irradiation or wind speed > 4 m/s)
Resolution	0.1 °K
Data Output Digital	
Interface	RS485 semi-/ full duplex, isolated
Baud rate	1200 ... 57600
Meas. rate instant. value	1 ... 10 s
Meas. Avg (arith., vec.), Min, Max	1...10 min
Status	Heating, sensor failure
Data Output Analog	
Data output analog	Semi-duplex mode
Output signal	0 ... 20 mA, 4 ... 20 mA, 0 ... 10 V, 2 ... 10 V, 2 ... 2,000 Hz (instantaneous, avg, min, max)
Load	Max. 300 Ω
Resolution	16 bit
General	
Bus operation	Up to 32 devices
Operating voltage	Power supply electronics: 12 ... 24 VDC ±10% Power supply electronics + heating: 12 ... 24 VDC ±10%
Electrical connection	8-pole plug
Ambient temperature	-40 ... 60 °C (with heating) / -20 ... 60 °C (without heating)
Dimensions and weight	Ø approx. 150 mm, height approx. 170 mm / approx. 0.8 kg
Protection type	IP66
Manufacturer	G. Lufft Mess- und Regeltechnik GmbH
Ammonit Meteo-40	RS485-M (Half duplex, 2-wire)
Accessory	Module set M83575 (set includes module M83570 and isolated repeater M84100)

# Ultrasonic Anemometer Lufft V200A-UMB

S85200H

## Sensor connection to Ammonit Meteo-40 data logger

Sensor	Plug Pin No.	Ammonit Cable Wire Colour (I)	Ammonit Cable Wire Colour (II)	Meteo-40 RS485 M	Supply Sensor
TXD/RXD-	2	brown	brown	RS485 A (-)	
TXD/RXD+	5	white	white	RS485 B (+)	
Control	3	green	green		
AGND	6	yellow	yellow		GND
Supply / Heating	8	red, pink	black 1,2		H1: 12 ... 24 VDC
Ground	7	blue, grey	black 3,4		H2: GND

Connect the shield logger-sided to Ground (GND)

(I) Cable type without heating: LiYCY 4 x 2 x 0.25 mm<sup>2</sup>

(II) Cable type with heating wires: CP 4 x 0.75 mm<sup>2</sup> + 2 x 2 x 0.14 mm<sup>2</sup>

## Sensor connection diagram to Ammonit Meteo-40 data logger

### Ultrasonic Anemometer Lufft 2D

V200A-UMB

Communication RS485 Half Duplex

